

# DEACTIVATOR

**ceco**

**COMPRESSOR  
ENGINEERING CORP.**

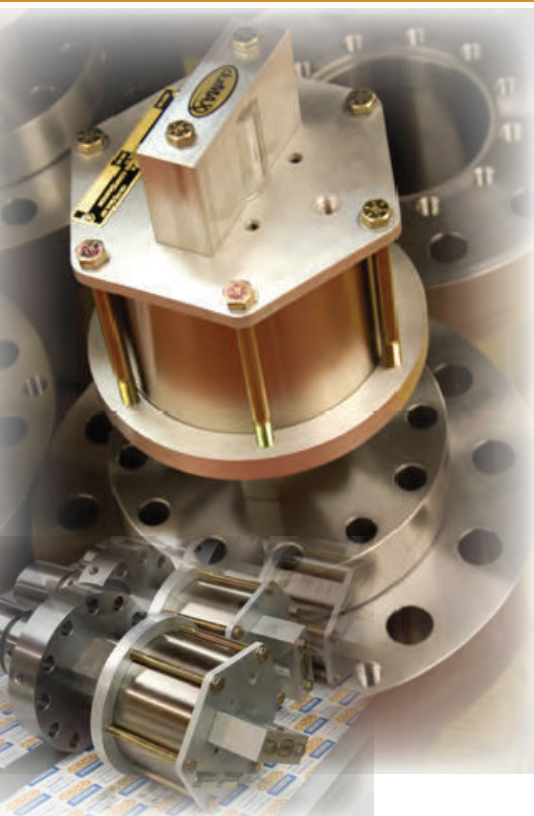

## REDUCE ENGINE LOAD

CECO's durMAX™ deactivator reduces engine load for optimum fuel efficiency. The plug-type design avoids inherent operational problems and breakage related to finger-type deactivators.

## UNIQUE DESIGN

Our deactivators unload one end of a compressor cylinder, avoiding driver overload and assist in maintaining 100% engine load for optimum fuel efficiency. The fail-safe design assures you that they will open on zero operating pressure, allowing for automatic unloading. We drill into the plunger in order to allow gas to flow and virtually equalize the pressure, reducing residual forces. The unloader piston does not feel the full effect of the cyclic pressure assuring long plunger and seat life.

## RUGGED RELIABILITY

The deactivator's operating shaft is made of noncorrosive high strength alloy steel. Two cast-iron rings guide the self-aligning plunger, allowing it to seal properly.

The plunger and guide are heat-treated 4140 steel and are hardened to provide long, problem-free operation. The operating cylinder has a noncorrosive wear surface for longer service life.

## ENGINEERED QUALITY

CECO has been delivering OEM Superior<sup>SM</sup> products and services to the gas transmission, gas processing and petrochemical industries since 1964.

The durMAX™ deactivators ship as a complete unit and ready to install. CECO offers experts to oversee the installation and train your station personnel to ensure the successful commissioning and operation of these custom-designed deactivators.

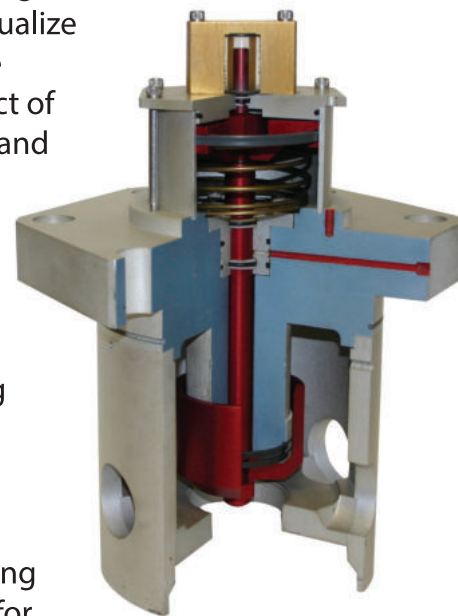

## ADVANTAGES

- Plug-type design
- Removable packing gland
- Working cylinder and plunger guide are integral
- Balanced piston design
- Fail-safe design API construction
- Upper cylinder parts interchangeable with clearance pocket actuator parts.

**durMAX**™